

ACCESSORIES



In extraction from silo



On a big bag station



On bag dumping station



Four shafts version for large blocks and high performances

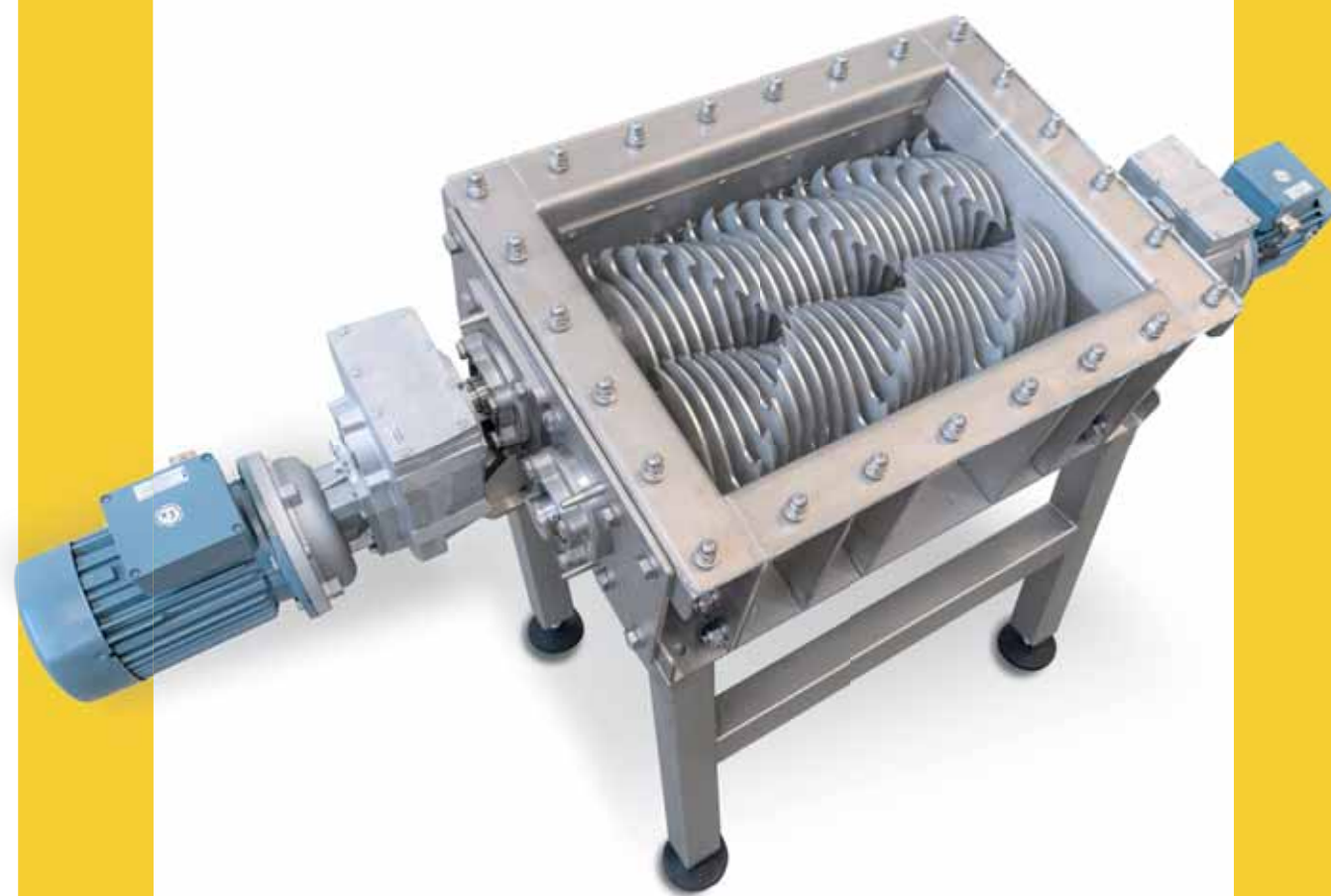

HAMMER CRUSHER LUMP BREAKER

Crushing blocks and lumps of hygroscopic products or reduction of particle size



TECHNOSILOS S.r.l.
Via Piana 67, 47032 Bertinoro (FC), ITALY
www.technosilos.com





Blade Shredder



Hammer Lump breaker



Blade Shredder (detail)



Hammer Lump breaker (detail)

Application

Elimination of lumps from hygroscopic products (e.g. sugar), shredding (e.g. dry pasta) or crushing of solid blocks to facilitate handling and use.

Operating principle

The product, introduced statically, is crushed by one or more rotating parts equipped with hammer tools or blades. The optional grid below allows the passage of the calibrated product.

Benefits:

Facilitates processing (e.g. grinding)

Prevents clogging of extraction systems.

Small size.

Simple installation in existing systems.

HAMMER CRUSHER LUMP BREAKER

- 1 Gear motor
- 2 Bearings
- 3 Shaft with blades/hammers
- 4 Selection grid
- 5 Machine body

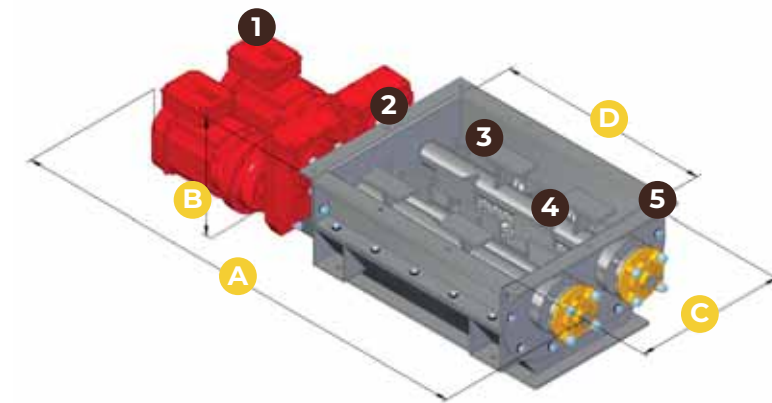
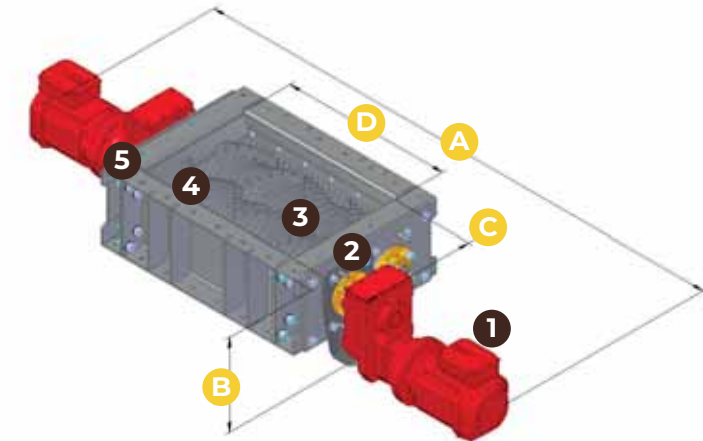

Dimensions

	Hammer crusher 400x600 mm	Lump breaker 400x600 mm
A	1925	1385
B	360	340
C	400	440
D	600	625