



COMPATTATORE DI SACCHI DAL DESIGN COMPATTO    SPACE SAVING COMPACTOR FOR EMPTY BAGS

## VANTAGGI

- Nessuna fuoriscita di polvere
- Design compatto
- Riduce il volume dei rifiuti
- Utilizzo in totale sicurezza
- Manutenzione ridotta e semplice
- Riduzione della manodopera

## BENEFITS

- No spillage of powder, no dust
- Compact design
- Reduced waste volume
- Safe operations
- Easy maintenance
- Reduced Labor



## CARATTERISTICHE TECNICHE / TECHNICAL CHARACTERISTICS

- Applicabile a tutte le tramogge vuotasacchi con cappa d'aspirazione
- Dimensioni corpo, 1227\*585\*505
- *Applicable to all dumping station with fixed dedusting hood*
- *Body Dimensions, 1227\*585\*505*

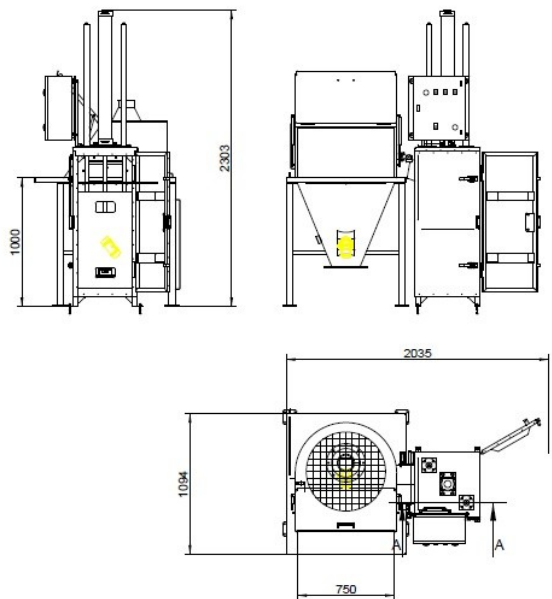

\* CONTATTARE L'UFFICIO TECNICO / \* CONSULT THE TECHNICAL DEPARTMENT

## ACCESSORIES



Portella con sensore di apertura  
*Interlocked access door*



Contenitore asportabile e apribile  
*Openable and removable waste bin*



Porta con sensore di apertura  
*Interlocked main door*



Con quadro di comando  
*With integrated control Switchboard*

TECHNOSILOS progetta e costruisce impianti di stoccaggio, trasporto, dosaggio di prodotti in polvere, granulari e liquidi, completi di sistemi di supervisione e automazione

*TECHNOSILOS design and build systems for storage, handling and batching of powdery, granular and liquid products, complete with supervision and automation systems.*

